

Vue F

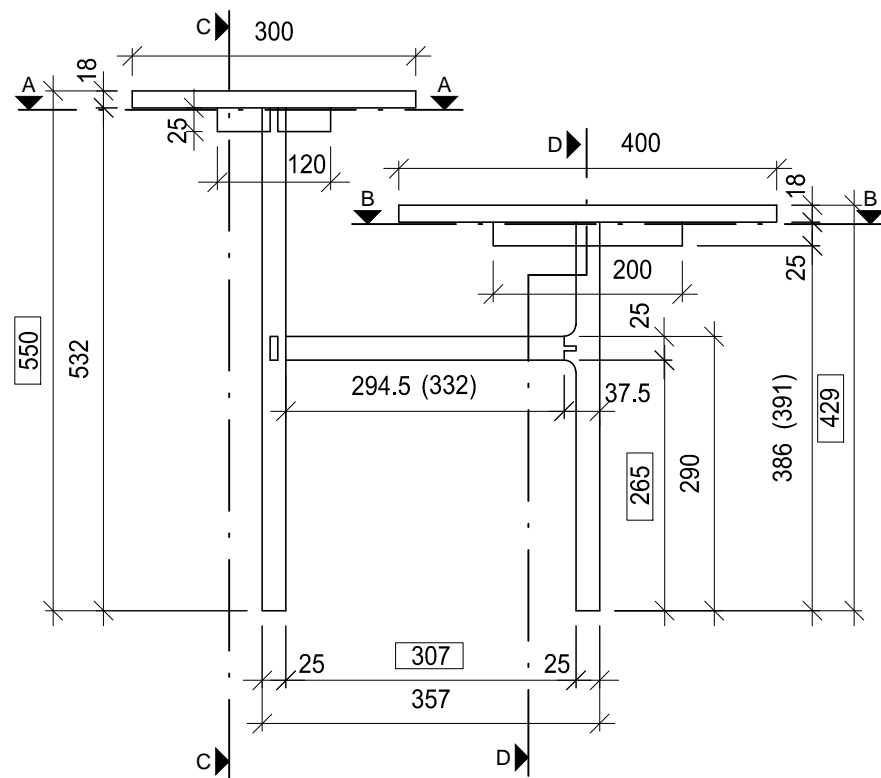

C-C

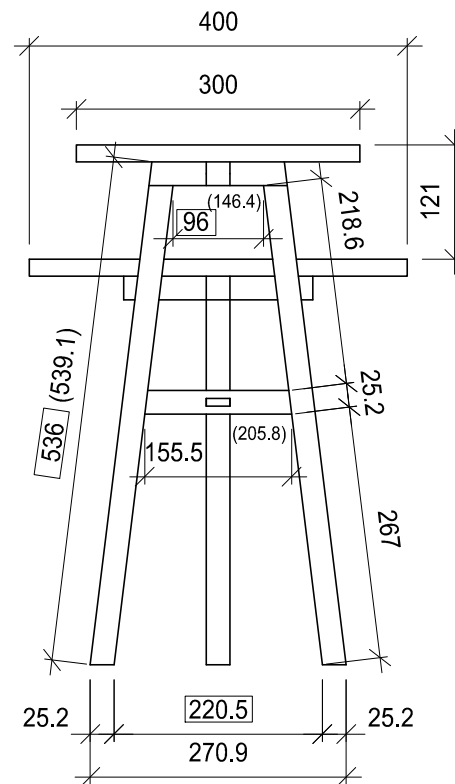

D-D

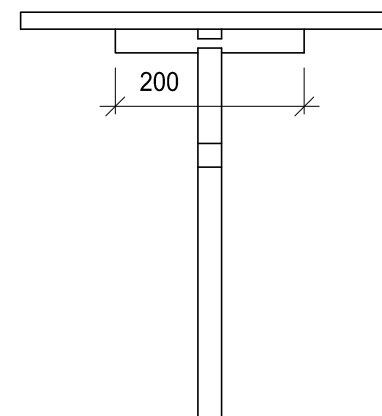

A-A

B-B

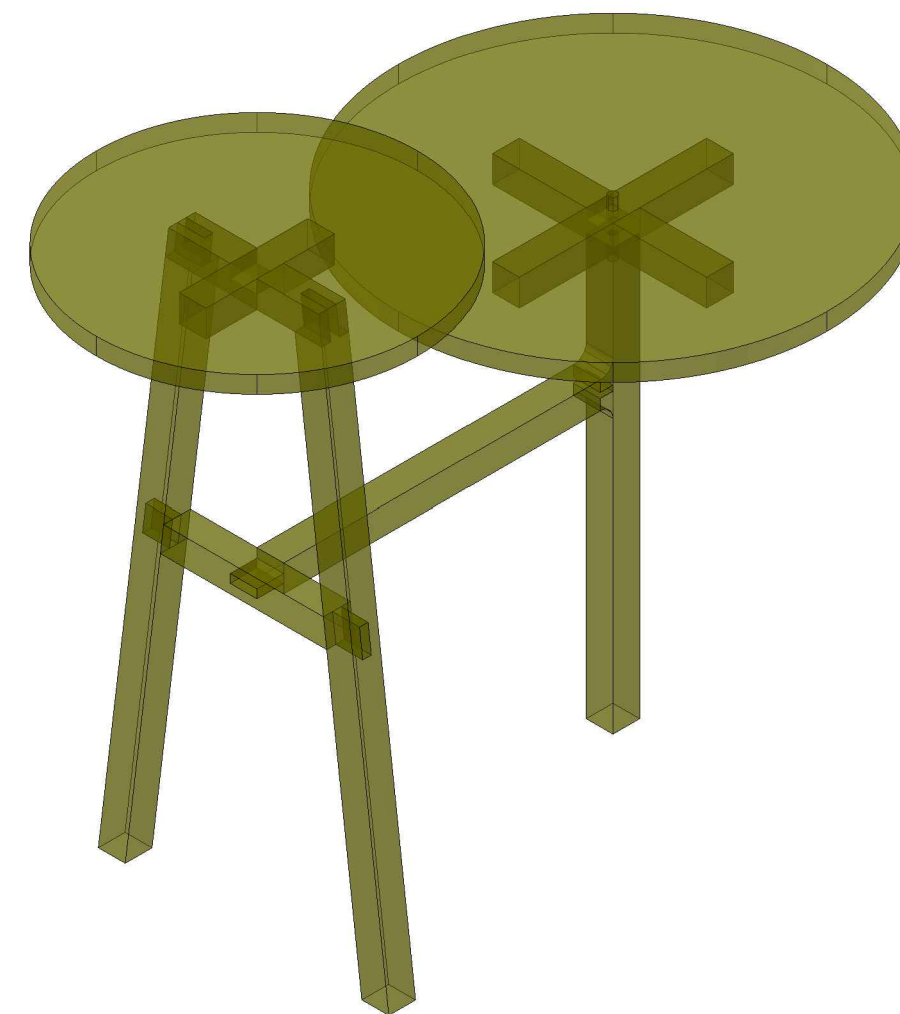
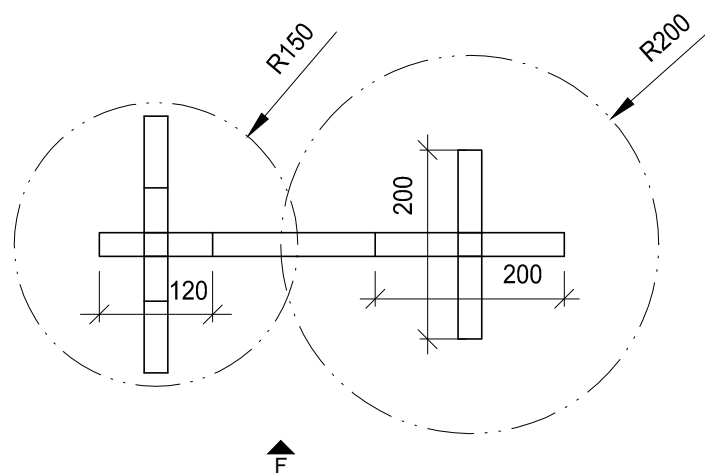

Liste de matériaux	Mat.	Pce.	Long.	Larg.	Epai.
Plateau	mult.	1	300	300	18
Plateau	mult.	1	400	400	18
Pied en biais	CHE	2	539.1	25	25
Traverse inter	CHE	1	205.8	25	25
Traverse haut	CHE	1	146.4	25	25
Support plateau	CHE	1	120	25	25
Traverse de liaison	CHE	1	332	25	25
Pied	CHE	1	391	50	25
Support plateau	CHE	2	200	25	25
Tourillon		1	Ø8x50		
Vis		8	VbTp 4x35		



Table d'appoint

Championnat cantonal
WS 2015/16

Fédération Suisse romande des entreprises de menuiserie
ébénisterie et charpenterie

Tâche n°: 2015.01-A

Echelle: 1:8 / 1:5

Dim. du plan: 290 x 420

Date: 04.09.2015

Dessin: ls